

TOMCAT®

CARBON

24" - 29" Scrubbers



RIDER SCRUBBERS SWEEPERS BURNISHERS CARPET CARE FLOOR MACHINES



KEY FEATURES



Machine Control Panel uses off-the-shelf toggle and marine duty switches and features universal icons which simplifies training.



Vacuum Muffler allows machine to consistently achieve as low as 62 dB while thoroughly drying the floor.



EDGE Orbital Scrubhead delivers premier chemical-free floor stripping while reducing water consumption by up to 70%.



Squeegee Adjustments made simple with quick change squeegee latch allows toolless maintenance and 4-sided squeegee blade.

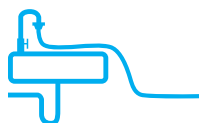

Front Fill System features a retractable hose for easy filling on standard sink-faucets.



High Performance motors and down pressure provides an unmatched standard of cleaning.



APPLICATIONS

School Systems

Healthcare

Warehouses

Grocery Stores

Retail

Automotive

Food Packaging

Airports

Sports Arenas

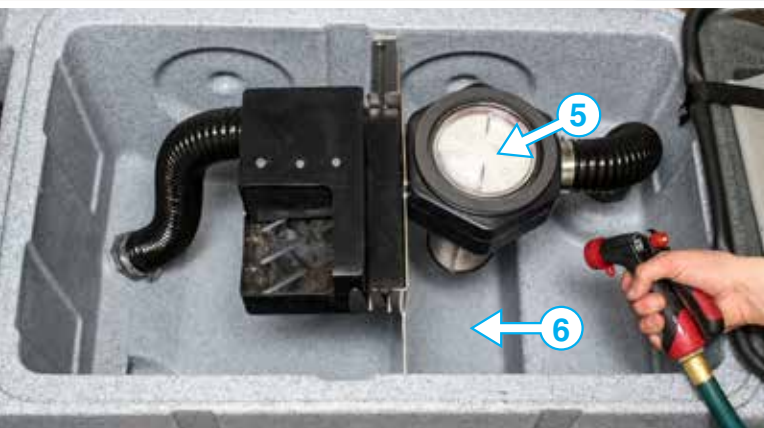
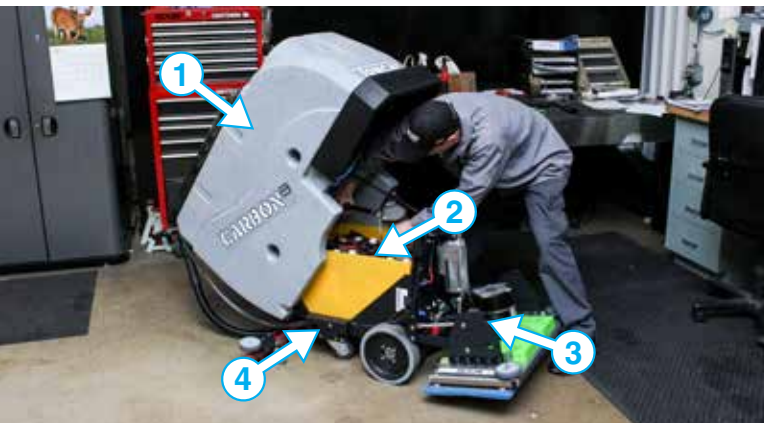

EASE OF MAINTENANCE

- 1 Tip Back "Clam Shell" Design
- 2 Access to Batteries
- 3 Access to Scrub Motors
- 4 Access to Solution Filter
- 5 White Vacuum Filter Access
- 6 Full Recovery Tank Access

VIEW INSIDE

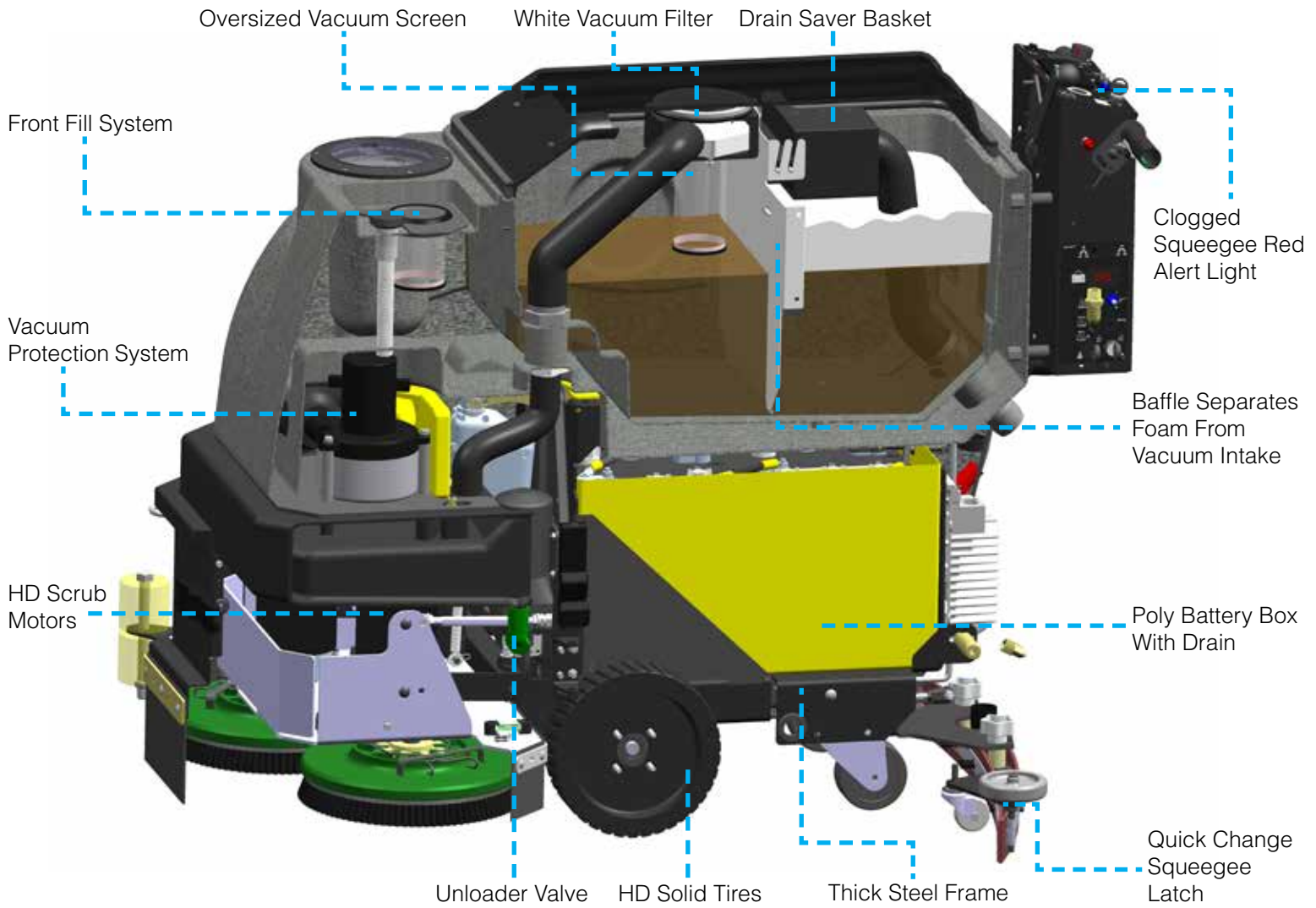

THREE SCRUB SYSTEMS TO CHOOSE FROM

DISK

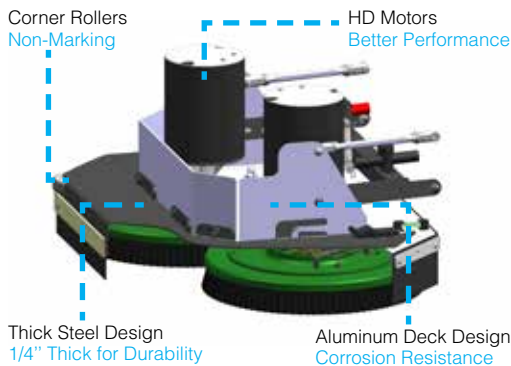

BENEFITS

- Brush / Pad Selection
- Lowest Maintenance Cost
- Gimballed Drivers Improves Cleaning On Irregular Floors
- Brushes Individually Driven For Unmatched Performance

CYLINDRICAL

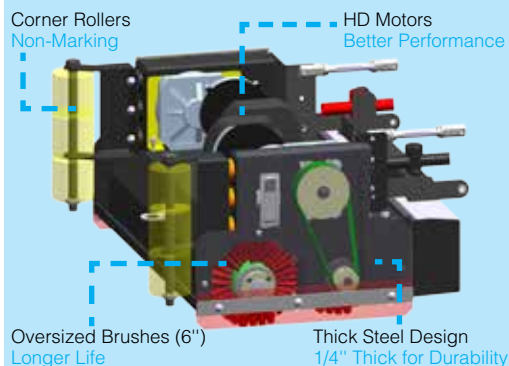

BENEFITS

- Eliminates Dust Mopping
- Scrub & Sweep Simultaneously
- Superior Grouted Tile Cleaning

EDGE

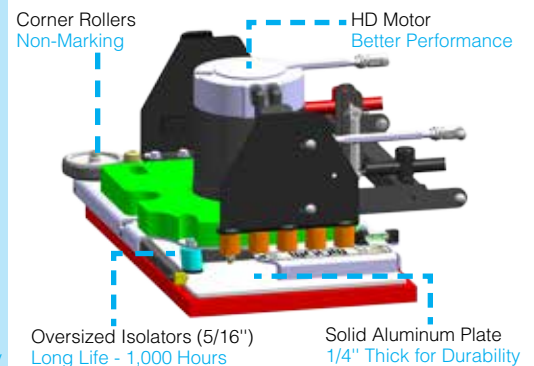

BENEFITS

- Chemical Free Stripping
- Reduce Slip & Fall Potential
- Earn LEED Credits
- 70% Reduction in Water Usage
- Consistent Results - No Swirl Marks
- Wet screens Wood Gym floors

CALL FOR A DEMONSTRATION

☎ 800-450-9824

🌐 (+001)-262-681-6470

🌐 www.tomcatequip.com

Since 1986, our family owned company has been designing, building and supporting the best in floor maintenance equipment. Our **TOMCAT** brand services the world with unsurpassed commercial cleaning equipment, continually exceeding expectations and setting the industry bar that much higher.

We've built our reputation by providing the highest value machines and providing local support via 425 distributors in over 42 different countries.

AUTHORIZED DISTRIBUTOR



Manufactured By:

R.P.S. Corporation
1711 South Street
Racine, Wisconsin 53404 (USA)
Phone: (800) 450-9824
International: (+001) 262-681-6470
www.tomcatequip.com

Copyright R.P.S. Corporation 2016. All rights reserved. Since our policy is one of constant improvement, all specifications are subject to change without notice.

BODY CONSTRUCTION / DIMENSIONS

Tank Material:	Poly 3/8" (10 mm)
Chassis Construction:	3/16" (5 mm) Powder Coated Steel
Front Wheels (Diameter x Width):	(2x) 10" x 2.5" ([2x] 25 x 6 cm) - Non-Marking Solid Grey
Rear Casters (Diameter x Width):	(2x) 4" x 2" ([2x] 10 x 5 cm) - Non-Marking Grey
Size (L x W x H):	52" x 22" x 40" (132 x 56 x 102 cm)
Weight (w/o Batteries):	393 - 443 lbs (178 - 201 kg)
Weight (w/ 210 ah Batteries):	625 - 675 lbs (284 - 306 kg)

BRUSH / PAD SYSTEM

Disk Dimensions:	26" - (2x) 13" Diameter (66 - [2x] 33 cm)
<small>Includes Jaws with Rollers for Wall Protection</small>	28" - (2x) 14" Diameter (71 - [2x] 36 cm)
Disk Motor:	(2x) 0.75 hp / 270 rpm ([2x] 559 watts)
Optional Motor Upgrade:	(2x) 1.0 hp / 350 rpm ([2x] 746 watts)
Disk Brush Speed:	270 rpm or 350 rpm
Cylindrical Dimensions:	25" - (2x) 6" x 23" (63.5 - [2x] 15 x 58 cm)
<small>6" Diameter Brush</small>	29" - (2x) 6" x 27" (73.7 - [2x] 15 x 69 cm)
Cylindrical Motor:	25" - (2x) 0.75 hp / 350 rpm ([2x] 559 watts)
	29" - (2x) 1.0 hp / 350 rpm ([2x] 746 watts)
Cylindrical Brush Speed:	750 rpm
EDGE Dimensions:	24" x 14" (70 x 36 cm)
	28" x 14" (71 x 36 cm)
EDGE Motor:	1.0 hp / 2500 rpm (746 watts)
EDGE Optional HD Motor:	1.2 hp / 2900 rpm (894 watts)
Scrub Pressure Actuator Rating:	500 lbs (227 kg)
Brush Pressure Settings:	(5) with Auto Adjust

POWER SYSTEM

System Voltage:	24 VDC
Standard Battery:	210 ah WET
Optional Battery:	245 ah WET / 250 ah AGM*
<small>*Includes Onboard Charger</small>	
Run Time:	Up to 3.5 Hours**
<small>**Run times are based on continuous scrubbing run times.</small>	
Charger:	120VAC / 60 Hz Input - 24VDC / 25 amp Output

DRIVE SYSTEM:

Power:	0.75hp - All Gear / Sealed (559 watts)
Forward Speed:	0 - 290 ft/min / 0 - 3.3 mph (0 - 88 m/min / 0 - 5 km/h)
Scrubbing Speed:	0 - 229 ft/min / 0 - 2.6 mph (0 - 70 m/min / 0 - 4 km/h)
Reverse Speed:	0 - 202 ft/min / 0 - 2.3 mph (0 - 62 m/min / 0 - 4 km/h)

SOLUTION / RECOVERY SYSTEMS:

Solution Tank Capacity:	16 Gallons (61 liters) - w/ Graduated Site Tube
XL Tank Option Solution Capacity:	21 Gallons (80 liters) - w/ Graduated Site Tube
Solution Flow / Filter:	0 - 0.7 GPM / Stainless Inline (0 - 2 LPM)
Recovery Tank Capacity:	17 Gallons (64 liters) - 1.5" diameter Drain Hose
XL Tank Option Recovery Capacity:	23 Gallons (87 liters) - 1.5" diameter Drain Hose
Demisting Chamber:	1.25 Gallons (5 liters)
Drain Saver:	30 cubic inches (492 cubic cm)
Vacuum Power:	0.8 hp / 3 Stage (640 watts)
Vacuum Specs (Water Lift / Airflow):	68" / 72 cfm (173 cm / 2 cm/m)
Squeegee:	36" Curved w/ 4-sided Rear Blade & Quick Change Latch Optional - 42" Squeegee

GENERAL:

Cleaning Width:	26" & 28" - Disk (66 & 71 cm)
	25" & 29" - Cylindrical (64 & 74 cm)
	24" & 28" - EDGE (70 & 71 cm)
Decibels:	62 dB
Productivity - Theoretical:	Up to 27,027 sqft (2,511 sqm)***
<small>***Productivity is based off of ISSA 2010 Cleaning Times</small>	
Productivity - Practical:	Up to 12,526 sqft (1,164 sqm)***
<small>***Productivity is based off of ISSA 2010 Cleaning Times</small>	